



Self-contained ice maker - Sprayer system Daily production up to 82 kg

Hotel	████████████████████
Restaurant	████████████████████
Fast food	████████████████████
Bar	████████████████████
Disco	████████████████████
Fish market	████████████████████
Supermarket	████████████████████
Medical & SPA	████████████████████
Industry	████████████████████

► Position n°



► Features & Plus

- Compact and crystal cube
- AISI 304 SS Scotch Brite finish
- Tropical class +43°C
- Adjustable Stainless Steel feet
- Removable and cleanable air filter
- Air or water cooling system
- Easy cleanable internal rounded surfaces
- HCFC-Free insulated storage
- RoHS Free
- Disappearing insulated door
- Electromechanical operation
- ON-OFF rocker switch
- Standard and special voltages
- HFC Free



AISI 304 SS Scotch Brite finish



Adjustable Stainless Steel feet



Removable and cleanable air filter



Disappearing insulated door

► Available ice cube size

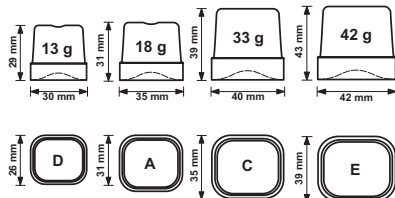

► Prod. 24h

Air temp.	Water temp.	kg	lbs		
		10° C	50° F	7° C	45° F
21° C	70° F	15° C	60° F	80	176

2 Years Warranty
subject to limitations

► Certifications available for this model





Ice Cube

CB 840 HC



Self-contained ice maker - Sprayer system Daily production up to 82 kg

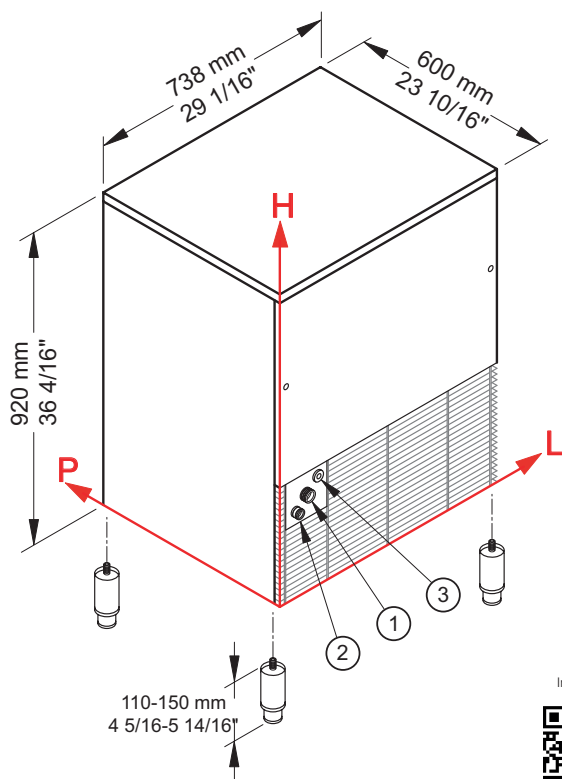

► Working conditions

- Location: **Indoor**

	Min	Max
Ambient temperature	+10° C / +50° F	+43° C / 110° F
Water temperature	+3° C / +37° F	+32° C / +90° F
Voltage	-10%	+10%
Water inlet pressure	1bar (14 psi)	6bar (84 psi)

► Performances

	Air temperature	Water temperature					
		7° C	45° F	15° C	60° F	21° C	70° F
	10° C	82 kg					
	50° F		181 lbs				
	21° C			80 kg			
	70° F				176 lbs		
	32° C					68 kg	
	90° F						150 lbs

► Connections

All measures are referred to the rear bottom-left corner (L-H-Ø)

- ① Water in.: 116 mm / 4 9/16" - 285 mm / 11 4/16" - 3/4" ② Water out.: 54 mm / 2 2/16" - 245 mm / 9 10/16" - 24 mm / 15/16"
 ③ Electrical connections: 161 mm / 6 5/16" - 321 mm / 12 10/16"

► Technical information

Production in 24h	80 kg / 176 lbs	Water consumption	A: 2 l/kg - 24 gal/100 lbs
Store capacity, up to	40 kg / 88 lbs		W: 13 l/kg - 156 gal/100 lbs
Cooling system	A - W	Sizes (L-P-H mm)	738 - 600 - 920
Kind of cube	A-18g, C-33g, D-13g, E-42g	(L-P-H in)	29 1/16 - 23 10/16 - 36 4/16
Refrigerant	R290	Sizes with pack (L-P-H mm)	780 - 640 - 1085
Standard voltage	220-240 V ~ 50 Hz	(L-P-H in)	30 11/16 - 25 3/16 - 42 11/16
Average power consumption	700 W	Net weight	86 kg / 190 lbs
Fuse	10 A	Gross weight	98 kg / 216 lbs
Electrical consumption	22 kWh/100kg	Finish	AISI 304 stainless steel, scotch brite

All the technical information must be considered at the following conditions:

- Sizes without feet
- Standard Cube (18 g)
- Ambient temperature +21° C
- Water temperature +15° C
- Electrical consumption at +32° C (standard voltage)
- Average power consumption at +43° C (standard voltage)

Models and specifications are subject to change without notice

Rev. 04 - Issued September 2019



www.bremaice.it
info@bremaice.it

Bim + Data
download

